

INCLUSION OF PEOPLE WITH DISABILITIES IN THE ELECTORAL PROCESS



SEPTEMBER 2014

Inclusion of people with disabilities in the electoral process

The publication of this report is made possible with the support of United States Agency for International Development (USAID) through the International Foundation for Electoral Systems (IFES). The opinions, findings and recommendations expressed herein are those of Democracy in Action and HandiKOS and do not necessarily reflect the views of donors.

| | |
|--|----|
| 1. DEFINITIONS | 4 |
| 2. EXECUTIVE SUMMARY | 5 |
| 3. SUMMARY OF ACTIONS REQUIRED TO MEET DISABILITY ACCESS STANDARDS FOR FUTURE ELECTIONS IN KOSOVO | 6 |
| A. Central Election Commission | 6 |
| B. Municipal Election Officers and Municipal Election Commissions | 7 |
| C. Political Entities | 8 |
| D. Election Complaints and Appeals Panel (ECAP) | 8 |
| E. NGOs, CSOs and CSO/PWDs | 9 |
| F. Other Stakeholders | 9 |
| 4. DISABILITY ACCESS MONITORING METHODOLOGY | 9 |
| 5. DISABILITY ACCESS AND INCLUSIVENESS STRATEGY | 11 |
| 6. LEGAL FRAMEWORK | 11 |
| A. The rights of persons with disabilities in elections | 11 |
| B. Informing persons with disabilities | 15 |
| C. Disability Access Complaints | 17 |
| D. Involvement of persons with disabilities in Election Administration | 18 |
| E. Voter registration for persons with disabilities | 19 |
| 7. MONITORING OF PRE-ELECTION AND ELECTION CAMPAIGN | 20 |
| A. Political entities and appointment of persons with disabilities as candidates | 20 |
| B. Platforms of political entities | 20 |
| C. Monitoring of political campaign events | 22 |
| D. Meetings with Municipal Election Commission Chairs and members | 26 |
| E. Polling Center pre-election visits | 27 |
| 8. MONITORING OF ELECTION DAY | 28 |
| A. Accessibility for persons with disabilities to Polling Centers | 28 |
| B. Accessibility for persons with disabilities inside Polling Centers | 29 |
| C. The voting process | 32 |
| C1. Persons with visual disabilities | 33 |
| C2. Persons with physical disabilities | 33 |
| 9. GOOD PRACTICES | 36 |

1. DEFINITIONS

Accessible - A site, facility, work environment, service or program that is easy to approach, enter, operate, participate in and/or use safely, independently and with dignity by persons with disabilities.

Accessible formats - Print, audio or visual information that is accessible to persons with disabilities.

Braille - Writing system comprised of raised dots used by people who are blind or have low vision.

Civil Society Organization of Persons with Disabilities (CSO/PWD) – an organization that is run by and promotes the interests of persons with disabilities.

Inclusion - Persons with disabilities are involved in all electoral activities on an equal basis with other citizens, including leadership positions, rather than just having accommodations that might segregate persons with disabilities from other citizens.

Intellectual disability - Term used when there are limits to a person’s ability to learn at an expected level and function in daily life.

Mobile Polling Team: is a service provided by the Central Election Commission on Election Day whereby a team of polling officials visits the houses of registered voters who cannot attend a polling station to enable them to cast a vote.

Persons with disabilities – according to Article 1 of the United Nations Convention on the Rights of Persons with Disabilities, includes those who have “long-term/permanent physical, mental, intellectual or sensory impairments which in interaction with various barriers may hinder their full and effective participation in society on an equal basis with others”.

Polling Center (PC) – a building in which one or more polling stations are located.

Political event - an activity organized by a political entity, such as a town hall meeting, door to door campaign, speech, presentation and similar, with the goal of promoting political messages inviting voters to support the entity in elections.

Polling Station (PS) – a room or similar facility used for voting and counting of votes on Election Day.

Ramp – An inclined plane or series of planes without obstacles to provide access to floor levels of different heights in the external and internal parts of a facility.

2. EXECUTIVE SUMMARY

According to estimates from organizations working with persons with disabilities there are around 200,000 persons with disabilities, out of a civil registry population of over 1.7 million in Kosovo. There has been little attention paid in Kosovo to the electoral rights of, or promoting electoral access for, persons with disabilities. Of approximately 80 permanent staff at the Central Election Commission (CEC), there are no people with disabilities engaged permanently at the central or municipal levels. There is also little representation of people with disabilities in administering elections at the polling station level or among observers nominated by political entities. For the early parliamentary elections held on June 8 in Kosovo, the project “Persons with disabilities monitoring their election rights” recruited 30 long term observers (LTOs) and 200 short term observers (STOs) with disabilities to monitor the pre-election period and Election Day.

The LTOs monitored 321 political events and conducted 45 Municipal Election Commission (MEC) visits during the 10-day election campaign period. The findings from observing the pre-election period in twenty of Kosovo’s largest municipalities suggest that only two political parties (Alliance for Future of Kosovo (AAK) and Vetevendosje Movement (LVV) nominated candidates with disabilities for the election. In 93% of the political events observed, there were no ramps or lifts to allow persons with disabilities to access the event. In only 11 of these events were there speakers who themselves had disabilities. Observers found that the MECs generally do not have a clear record of the number of persons with disabilities residing in their municipalities, and found no community-based voter information activities at the local level organized by the electoral authorities specifically targeting voters with disabilities.



Call center team processing Election Day DAM reports

On Election Day, STOs covered 520 of the 798 polling centers in Kosovo. The results from Election Day show that in 37% of Polling Centers observed, walkways and sidewalks in the voting area were not accessible. Meanwhile inside the polling centers, in only 54% of polling centers visited was there obstacle free maneuverability for wheelchair users, and in 61% toilets were not accessible to people with disabilities. On the other hand, the CEC has made efforts to ensure that polling centers are equipped with Braille ballot marking guides for voters with visual

disabilities, even though they were not found to be available in all polling stations (PSs) visited. The CEC promotes voting through mobile teams for voters who are unable to physically go to a polling station. However, the number of persons with disabilities who have used this service is low (1,347 voters). This can be largely attributed to the lack of targeted awareness campaigns, and registration procedures for using mobile teams that require voters with disabilities to submit applications to municipal office premises, which are not always accessible.

The existing legal framework, including the Law on General Elections and CEC regulations, guarantees equal rights for persons with disabilities, and it is the responsibility of the CEC to establish the necessary procedures and to undertake activities to guarantee that all persons with

disabilities can exercise their right to vote and to participate in the electoral process in Kosovo. However the mechanisms that ensure accessibility and the right to vote freely and independently are limited and not always effective, as the results of the observation of this election indicate.

This Disability Access Monitoring (DAM) project for elections, which is the first of its kind in Kosovo, aims to identify and support new and improved practices to promote the active involvement of persons with disabilities in electoral processes, and to contribute to the advancement of persons with disabilities in society as equal members

3. SUMMARY OF ACTIONS REQUIRED TO MEET DISABILITY ACCESS STANDARDS FOR FUTURE ELECTIONS IN KOSOVO

The findings of the Disability Access Monitoring project for the June 8, 2014 national elections in Kosovo indicate that the following actions are required for disability access standards to be met in future elections in Kosovo.

A. Central Election Commission

1. Develop a Disability Access and Inclusiveness Strategy within the next twelve months, in consultation with Civil Society Organizations for Persons with Disabilities (CSO/PWDs) and other stakeholders.
2. Ensure that the current legal and regulatory framework pertaining to persons with disabilities is implemented at both the local and national levels.
3. Ensure that the CEC and all MEC offices meet accessibility standards for persons with disabilities.
4. Provide an online platform for registration for mobile polling services of persons with disabilities who cannot attend municipal premises, and promote it among CSO/PWDs.
5. Review CEC policies for determining the eligibility of voters for mobile polling services to ensure that these result in comprehensive coverage of voters with disabilities who would have difficulty accessing polling stations.
6. Conduct assessments of each polling center and polling station prior to each election and take action to ensure that all meet disability access standards, or that alternative premises that can meet these standards are used.
7. Develop a mapping platform which records all disability access issues for each polling center and electoral activity location.
8. Amend the CEC regulations on the establishment of polling centers and provide voting and other electoral services to persons with disabilities in order to provide them with greater access to electoral processes.

9. Revise polling equipment specifications and set-up instructions to ensure persons with physical disabilities can access voting compartments and ballot boxes to vote in secret and without assistance. Consider the provision of one table-top voting compartment per polling station.
10. Ensure that magnifying glasses and good quality Braille and/or tactile ballot marking guides are supplied to all polling stations to improve election access for persons with visual disabilities.
11. Ensure that the Braille ballot guides reach every polling center and that polling station commissioners are trained for their use.
12. Improve cooperation with CSO/PWDs in areas such as voter information, registration of persons with disabilities, deployment of mobile polling teams, in order to increase election participation among voters with disabilities.
13. Review whether the activities and means used by the CEC to motivate participation by voters with disabilities and inform them fully of their electoral rights, and their scheduling, have been effective.
14. Implement electoral information activities specifically targeting persons with disabilities, and develop specific electoral information materials that are accessible for people with physical, hearing, visual or intellectual disabilities.
15. Respect Kosovo's "1 in 50" rule, which requires that one in fifty employees must be a person with a disability, including by designating within the CEC Secretariat a permanent position with responsibility for inclusiveness and potentially filled by a person with a disability.
16. Ensure that persons with disabilities are engaged, in numbers at a minimum sufficient to meet the '1 in 50' rule, as temporary staff during the election period, including as CEC trainers, help desk officers, by-mail processing and Count and Result Center staff, and by enforcing this requirement for nominees by political entities to Municipal Election Commissions and Polling Station Commissions.

B. Municipal Election Officers and Municipal Election Commissions

17. Ensure more regular attention is paid to issues affecting electoral access for persons with disabilities by Municipal Election Officers (MEOs) and MECs. This is more likely if political entities and the CEC ensure that there is more widespread representation of persons with disabilities in MEO and MEC positions.
18. MEOs and MECs, in coordination with local NGOs and CSOs (including CSO/PWDs), should implement local electoral information activities targeting persons with disabilities, using methodology and content appropriate for each type of disability.

19. MEOs and MECs can build stronger links with communities of persons with disabilities to have better knowledge of potential voters with disabilities in the municipality and of the electoral services they need.

C. Political Entities

20. Regularly review political platforms and policies in consultation with CSO/PWDs to ensure that the policies address the concerns of persons with disabilities.
21. Hold regular consultation meetings with CSO/PWDs to discuss and advance policies on persons with disabilities.
22. Review the entity's internal statutes and rules and take action to ensure that persons with disabilities are included in party executive and administrative structures, and policy and decision-making processes.
23. Ensure that persons with disabilities are included in the entity's candidate lists for national and municipal elections.
24. Ensure that all political entity administrative offices meet accessibility standards for persons with disabilities.
25. Ensure persons with disabilities are encouraged to be actively engaged in party administration and activities such as policy development, organizing campaign events, and developing and distributing campaign materials.
26. Ensure that at least 10% of the persons nominated from the entity for positions on MECs and Polling Station Commissions (PSCs), and engaged by the party as observers or for other election related work, are persons with disabilities, to reflect the percentage of persons with disabilities living in Kosovo.
27. Publicize political campaign events among CSO/PWDs, and provide campaign information that is accessible for people with physical, hearing, visual or intellectual disabilities, including using accessible venues for campaign events.

D. Election Complaints and Appeals Panel (ECAP)

28. Ensure that facilities for lodging election complaints, providing evidence related to the complaint and attendance at ECAP hearings are accessible to people with disabilities.
29. Ensure that ECAP information campaigns inform voters of their rights to lodge complaints on disability access issues and use information materials that are accessible for people with physical, hearing, visual or intellectual disabilities

E. NGOs, CSOs and CSO/PWDs

30. Continue implementing projects to promote the electoral rights of persons with disabilities, including disability access monitoring for future elections, and engage persons with disabilities to manage and implement them.
31. Regularly update the register of persons with disabilities within each CSO/PWD, promote a national integration of this data and cooperate with election management bodies to support registration, voter information and mobile team voting for persons with disabilities.
32. Monitor the extent to which the political entities and election management bodies address issues related to persons with disabilities in policies and during campaigns, and implement advocacy activities to ensure the rights of people with disabilities are respected.

F. Other Stakeholders

33. Ensure that the current legal and regulatory framework pertaining to persons with disabilities is implemented at both the local and national levels, and consider improving the framework to consolidate and protect the rights of persons with disabilities.
34. Ensure that the legal framework guarantees the right to lodge a complaint against any barriers to access for persons with disabilities to the election process, and that ECAP and other judicial authorities are granted powers to undertake remedial actions.
35. Ensure that state administration bodies, private sector employers and NGOs comply with the requirement of Law 3/L-019, to employ at least 1 person with a disability in every 50 employees.
36. Review civil registration procedures to allow, in accordance with requirements for protecting private information, the recording of information about a citizen's disability in the civil register, in order to assist state authorities, including the CEC, to provide better targeted services to persons with disabilities.
37. Conduct assessments of public buildings, including government agencies, local and central civil registration offices, educational facilities, and cultural and sports halls, to ensure they meet disability access standards.

4. DISABILITY ACCESS MONITORING METHODOLOGY

As well as monitoring accessibility to voting on Election Day, the disability access monitoring program included a series of other activities designed to monitor the electoral environment, focusing more comprehensively on areas such as: the extent to which the legal framework safeguards the rights of persons with disabilities; the extent to which political party campaigns address issues dealing with persons with disabilities; the extent to which the CEC provides services to persons with disabilities; the extent to which persons with disabilities are represented in political party candidate lists, and to which they are engaged as temporary staff in administering the elections.

To conduct such monitoring, 30 long term observers (LTOs) were deployed from May 28 to June 8 to cover the pre-election period in the twenty largest municipalities of Kosovo. The LTOs made 45 visits to MECs, attended 321 political campaign events and made visits to 117 polling centers throughout Kosovo. Additionally, 200 short term observers (STOs) were deployed on Election Day covering most of the municipalities of Kosovo, with the exception of: Zvečan/Zvečan, Zubin Potok, Leposavič/Leposavić as there was no observers from these areas; and Dragash/Dragaš, Junik/Junik and Mamush/Mamuša which were excluded as a result of the sampling methodology.



Training session for disability access monitors, Prishtina

Each STO was assigned to monitor at least three polling centers on Election Day, covering 600 of the total 798 polling centers in Kosovo. The selection of the 600 polling centers was done using randomized sampling methodology. First, a proportion of the polling centers to be covered for each municipality was determined from the list of all polling centers (excluding polling centers from Zvečan/Zvečan, Zubin Potok, Leposavič/Leposavić). Then, for each municipality, the polling centers were selected from the list using randomized number generator. There were two limitations in

coverage: first, after drawing the sample of the polling centers, some twenty polling centers that were in remote or mountainous areas were replaced by polling centers that were easier to reach for observers with disabilities; second, not all of the sampled 600 polling centers could be visited on Election Day, though observers managed to cover 520 of them.

Both long term and short term observers were trained before deployment. The training provided information about key aspects of the elections in Kosovo, and largely focused on areas that observers should monitor and the completion the monitoring checklists. The checklists used by the observers were based on the forms used internationally by the General Election Network for Disability Access (AGENDA), and were adapted to the electoral environment in Kosovo.



Training session for disability access monitors, Prishtina

Specific checklists were used for monitoring the electoral and legal environment, meetings with CEC and MECs, political entity campaign events, pre-Election Day polling center visits and Election Day monitoring.

The checklists consisted mainly of closed-ended questions where observers had to circle between Yes or No options, and where appropriate space was provided for observers to elaborate on their answer. The data from all the forms were compiled, rechecked and cleaned, and analyzed to

provide the comprehensive charts in this report. It is important to note that sometimes observers were not able to answer all questions in the form, leaving some of the answers blank. The blank answers were excluded from the results of this report, which is why the number of polling centers from which data was obtained varies among different charts presented in this report.

The legal framework that was analyzed includes the Constitution of Kosovo, Law on General Elections, Central Election Commission regulations pertaining to persons with disabilities, and administrative directives for access for persons with disabilities. Additionally, meetings were held with the CEC Secretariat staff to gather information about CEC’s resourcing, practices and efforts to improve electoral access for persons with disabilities.

5. DISABILITY ACCESS AND INCLUSIVENESS STRATEGY

The results of the disability access monitoring for the June 8 national elections found a number of ad hoc efforts by the CEC and its stakeholder partners, to support access by persons with disabilities to electoral processes. CEC regulations deal with disability issues, but at times as part of a broader accessibility approach rather than focusing on persons with disabilities. Physical access to electoral facilities and electoral employment, while in general is mandated in the legal framework, is inconsistently applied in practice. The monitoring also found that political entities in general do not have a considered approach to dealing with persons with disabilities, in areas such as promoting access to their campaign events, tailoring policies and information campaigns and inclusion in candidacy and nominations for electoral positions. To develop a focused and integrated approach on these and

related issues, the CEC can take the lead in developing, with stakeholder input, a strategy to enhance the inclusion, access and participation of persons with disabilities in electoral affairs.



Shpend Krasniqi casting a ballot on Election Day

Shpend Krasniqi, 31, suffered an accident three years ago that has left him in a wheelchair. His engagement as an observer in this project has made him break the psychological barriers and for the first time he left his home without a carer. "It is an inexpressible feeling for me that I could give something to society. We need such projects that make us independent, motivate us to contribute to society, and change our lives. For me it has truly been a useful exercise to measure my abilities to work in the future".

Action:

The CEC should develop a Disability Access and Inclusiveness Strategy within the next twelve months, in consultation with Civil Society Organizations for Persons with Disabilities (CSO/PWDs) and other stakeholders.

6. LEGAL FRAMEWORK

A. The rights of persons with disabilities in elections

The United Nations Convention on the Rights of Persons with Disabilities, Article 29, calls on states to ensure that persons with disabilities can effectively and fully participate in political and public life on an equal basis with others, directly or through freely chosen representatives, including having the right and opportunity to vote and be elected.

The Constitution of the Republic of Kosovo is based on principles that recognize and guarantee the rights of persons with disabilities including the right to vote. Chapter II of the Republic of Kosovo Constitution, and in particular Article 45, guarantees to each citizen of Kosovo reaching the age of eighteen (18) to enjoy the right to vote and to be elected, that the vote is personal, equal and secret, and that state institutions support the possibilities for participation and decision making in political processes.

According to Article 2 of the Law on General Elections (LGE) in Kosovo each citizen has the right to vote and to be elected without discrimination. Furthermore, Article 59.3 (c) of the LGE specifies that it is the responsibility of the CEC to establish necessary procedures and to undertake activities to guarantee that all persons with disabilities can exercise their right to vote and to participate in the election process in Kosovo.

On the other hand, Article 5.2 (c) of the LGE states that no person can vote if he or she has been declared mentally incompetent by a final court decision. There is no data available on the number of persons who have been declared mentally incompetent, and no research has been done to assess whether this provision has unreasonably prevented anyone from voting.

The CEC organizes the voting of persons with ‘special needs’ using mobile polling teams, in accordance with the provisions of Chapter XV of the LGE. More specifically, in July 2013, the CEC approved Election Regulation 04/2013 on Voting of Persons with special needs and circumstances, where among other ‘special need’ voter categories, provisions for people with disabilities to utilize voting through mobile polling teams are included. Voting by persons with ‘special needs’ does not apply exclusively to persons with disabilities, although this is often confused in practice. Voting for persons with ‘special needs’ is also organized for aged people in specified homes and for persons located in residential institutions, prisoners, and for persons who for security or other reasons cannot vote at a polling station. Revision of the legal and regulatory framework should be considered in the future, in order to avoid using the term ‘special needs’, for persons with disabilities. This will support harmonizing Kosovo legislation on disability issues with the terminology that is applied globally.

Persons with disabilities or with a severe medical condition who wish to vote through the mobile polling teams on Election Day are required to submit their application to the CEC for using such services. The application is done by submitting a completed application form that can be obtained from the CEC website or an MEC office, and attaching a copy of a valid identification document and a certificate of disability or medical diagnosis. The applicant is required to submit the application in-person at the MEC office, unless a registered CSO/PWD with expertise in assisting homebound persons collects applications and submits them to the CEC Secretariat.

For persons with disabilities to obtain valid identification documents, and apply for voting through the mobile polling teams, it is necessary that municipal registration offices and municipal election offices be accessible for people with disabilities. The observation found that some MEC offices were inaccessible to persons with disabilities, even if they were able to travel to the municipal center where the office is located.

In regular elections, the CEC Regulation 04/2013 allows a 45 day registration period for voters with 'special needs' who wish to apply for voting through mobile polling teams. However the 2014 parliamentary elections were early elections, for which the CEC had to compress the timeline to adhere to a 31 day election preparation period. As a result of a CEC decision of May 8, 2014, the period for registering voters with 'special needs' was reduced to 10 days, from May 20 to May 29. During this period 1,347 voters with disabilities individually registered. Prior to the November 2013 local elections the CEC had relied on lists of homebound persons provided by HandiKOS, which typically contained the names of 4,000 to 5,000 potential homebound voters. However, the CEC discontinued this practice and instituted an individual registration process as it believed that there were inconsistencies in the data provided by HandiKOS. However this has resulted in a very large decrease in the numbers of people classified as homebound and able to access mobile polling services.

Action:

Ensure that the CEC and all MEC offices meet accessibility standards for persons with disabilities.

Provide an online platform for registration for mobile polling services of persons with disabilities who cannot attend municipal premises and promote it among CSO/PWDs.

Review CEC policies for determining the eligibility of voters for mobile polling services to ensure that these result in comprehensive coverage of voters with disabilities who would have difficulty accessing polling stations.

Article 83.6 of the LGE provides that polling stations must be in an accessible place to enable the voters to queue and when possible to have level access so persons with disabilities have unhindered entry and exit. Similarly, Article 3 of CEC Regulation 16/2013 on the establishment of polling centers, provides that polling center locations must fulfill criteria to ensure easy access for persons with disabilities on Election Day. According to data from this disability access monitoring project and additional data from the Democracy in Action (DiA) election observation, out of 798 polling centers used for the June 8, 2014 elections, 45% were not accessible to persons with disabilities.

With regard to voting assistance for persons with disabilities, Article 89.5 of the LGE provides that another person chosen by the voter can assist a voter with disabilities or who is not literate, who is not able to write or cast the ballot, if he/she requires such assistance. Such person may assist only one voter and cannot be a member of the Polling Station Commission (PSC) or an accredited observer. However such assisted voting breaches the rights of persons with disabilities to ballot secrecy: highly preferably, the CEC's standards for ballot and polling equipment design and polling station layout would enable persons with disabilities to vote without assistance.

Action:

Conduct assessments of each polling center and polling station prior to each election and take action to ensure that all meet disability access standards, or that alternative premises that can meet these standards are used.

Develop a mapping platform which records all disability access issues for each polling center and electoral activity location.

Amend the CEC regulation on the establishment of polling centers and provide voting and other electoral services to persons with disabilities in order to provide them with greater access to electoral processes.

Revise polling equipment specifications and set-up instructions to ensure persons with physical disabilities can access voting compartments and ballot boxes to vote in secret and without assistance. Consider the provision of one table-top voting compartment per polling station.

Ensure that magnifying glasses and good quality Braille and/or tactile ballot marking guides are supplied to all polling stations, to improve election access for persons with visual disabilities.



CEC Press Conference, June 4, 2014

In the past few years, issues pertaining to disability access have been brought to the attention of the CEC by numerous CSO/PWDs. Enabling people with disabilities to vote through mobile polling teams is one of the issues that HandiKOS has advocated for since 2000. Voting using Braille ballot templates is another accomplishment that the CEC has applied since 2009 for visually impaired voters. On June 4, 2014, through a press conference, the CEC reiterated its commitment to continuing to provide equal voting opportunities for visually impaired voters.

Communities of persons with disabilities in Kosovo promote their interests through various CSO/PWDs such as HandiKOS, Kosovar Association of the Deaf, Kosovo Association of the Blind and the Organization of Those Affected by Autism or Down Syndrome. No significant efforts have been made by the CEC or MECs or MEOs to coordinate with or engage CSO/PWDs in areas such as voter education, registration of persons with disabilities, and deployment of mobile teams, in order to increase election participation among voters with disabilities. These associations are generally neglected by government institutions and political parties. Funding for CSO/PWDs to implement disability projects continues to be challenging. Although the legal framework pertaining to disability access in elections is considered favorable to some extent, there are significant gaps in adherence to the law, as the findings of this report show.

CSO/PWDs' capacities in monitoring the electoral process or promoting electoral rights for people with disabilities are low and their engagement in existing civil society election monitoring networks is minimal. Sporadic efforts have been made by some CSO/PWDs in mobilizing their communities to participate in the electoral process; however there is no integrated CSO strategy to support the electoral rights of people with disabilities.

Action:

Improve cooperation with CSO/PWDs in areas such as voter information, registration of persons with disabilities, deployment of mobile polling teams, in order to increase election participation among voters with disabilities.

Continue implementing projects to promote the electoral rights of persons with disabilities, including disability access monitoring for future elections, and engage persons with disabilities to manage and implement them.

B. Informing persons with disabilities

The election legal framework includes a number of provisions that oblige the election management bodies to provide accessible information materials to persons with disabilities as part of the overall voter information campaign. Article 107.3 of the LGE provides that the CEC Secretariat should pay special attention to voters in rural areas, persons with disabilities and persons of low literacy, during the education campaign. In addition, Article 108.1 and .2 requires that the CEC prepare adequate



DiA/HandiKOS Motivational TV Spot

materials that allow for transmission of information to people with hearing disabilities. The legal framework does not envisage any targeted approach for persons with intellectual or visual disabilities. In practice, each disability type needs a specifically targeted information approach: effective methods of information transfer will be different for each disability type, and the information content may also be different. The information needs of persons with intellectual disabilities require particular attention.

The CEC's public outreach campaign was particularly successful in informing persons with hearing disabilities, as most of the TV spots included sign language. On the other hand, there were no information activities targeted for people with visual and intellectual disabilities. There were no large format print materials for people with limited vision, and there were no informational materials provided for persons with visual disabilities who do not read braille. Similarly, targeted information activities for people with intellectual disabilities were lacking, which is why it would be useful for the CEC to consider improving coordination with organizations working with and for persons with intellectual disabilities.

-
1. The complaint related to the village of Kmetovc, Municipality of Gjilan/Gjilane, where the mobile team did not manage to get to the address of a voter with a disability, as someone in the village told them she had passed away.
 2. <https://www.youtube.com/watch?v=J-0doXPtMY4#t=16>

Complaints and Appeals Commission (ECAP) broadcast TV and radio spots to inform voters about complaint procedures, although they were not fully accessible to persons with hearing disabilities. ECAP has received only one complaint regarding disability access to the June 8¹ elections. The lack of complaints could be influenced by the lack of information about the complaint procedures that is accessible to persons with disabilities, and could also be affected by problems for persons with physical disabilities to access the ECAP premises, where complaints must be lodged. Moreover, the complaint forms are not accessible to persons with visual disabilities.

During the registration period for voters with ‘special needs’ the CEC implemented a campaign to inform voters about the registration and voting procedures for mobile polling teams. The tools which the CEC used to inform voters were TV spots², radio spots, brochures³, billboards, and information desks that were placed in all municipalities of Kosovo. The materials were immediately made available on the CEC website. The TV spots included sign language for persons with hearing disabilities and were broadcast on average three times per day on each of the three main television stations (RTK, KTV and RTV21) from 20-28th of May. The broadcast dates coincided with the dates of the mobile polling registration period (20-29th of May), although commencing this information campaign before the registration period commenced and running it to the end of the registration period may be more effective.

The CEC contracted the Kosovo Association of the Blind (KAB) representatives to train their members on how to vote using Braille guides. Instruction booklets in Braille and audio versions of these booklets containing all political entity candidate lists for the June 8 elections were made available to KAB at central and local levels. The same printed and audio materials were distributed to the help desks of each polling center on Election Day. In addition, the CEC contracted KAB to print the booklet and ballot templates in Braille, given the lack of experience among printing houses to print materials in Braille.

According to Election Day observers there was a low turnout among persons with disabilities. This could be influenced by the lack of motivational campaigns to encourage the participation of persons with disabilities, lack of information provided to voters with disabilities of their electoral rights, and lack of information provided in forms accessible to persons with disabilities about the voting and complaints procedures. Regular coordination meetings between the CEC and CSO/PWDs would allow the expertise and input of CSO/PWDs to be included in producing awareness campaigns that are specifically tailored for each disability category.

To augment the CEC efforts in voter education, with the support of IFES and USAID, Democracy in Action (DiA) and HandiKOS developed a TV spot⁴ that was broadcast on the main TV channels during the electoral campaign period, aiming to promote promote electoral access for people with disabilities, and motivating them to vote. Through this spot, spokespersons of HandiKOS conveyed strong messages to the public, such as “votes of 200,000 people with disabilities count”, “I will vote and observe” and “get out to vote”. The TV spot, also available in sign language, was also posted on Youtube, and the DiA and HandiKOS websites. Additionally, 9,000 flyers and 2,500 leaflets with the

1. The complaint related to the village of Kmetovc, Municipality of Gjilan/Gjilane, where the mobile team did not manage to get to the address of a voter with a disability, as someone in the village told them she had passed away.

2. <https://www.youtube.com/watch?v=J-0doXPtMY4#t=16>

3. http://www.kqz-ks.org/Uploads/Documents/Fletushke-Tek-sti%20per%20periudhen%20e%20Personave%20me%20nevoja%20te%20veqanta-shqip_nyvkhwglwk.pdf

4. <https://www.youtube.com/watch?v=IVbK4ATpNF0&feature=youtu.be>

same theme were developed and disseminated throughout Kosovo via DiA's network of observers and HandiKOS regional offices.



DiA/HandiKOS Brochure and Leaflets

Action:

Review whether the activities and means used by the CEC to motivate participation by voters with disabilities and inform them fully of their electoral rights, and their scheduling, have been effective.

Implement electoral information activities specifically targeting persons with disabilities, and develop specific electoral information materials that are accessible for people with physical, hearing, visual or intellectual disabilities.

Ensure that ECAP information campaigns and materials are specifically designed for and targeted to voters with physical, hearing, visual or intellectual disabilities to inform them on their rights to submit complaints on disability access issues during the electoral process.

C. Disability access complaints adjudication

The LGE does not provide a solid framework for persons with disabilities to make an electoral complaint. In addition, there are no clear local and central mechanisms through which persons with physical disabilities could file a complaint if the facilities do not provide access. Specifically, there is lack of clarity in terms of who should be monitoring the implementation of the Administrative Instruction for technical conditions that buildings should have to enable access for persons with disabilities.

While Article 119.1 of the LGE provides that a person whose rights concerning the electoral process have been violated may submit a complaint to ECAP, it is unclear whether this provision guarantees the right for a person with disability to complain on matters related to accessibility of the polling center or polling station on Election Day, access to mobile polling, or access to information about the election. Even if such a complaint is accepted by ECAP, there are no legal provisions that provide ECAP with powers to impose sanctions or remedial actions on election management bodies or other authorities. ECAP would therefore not be able to decide or take any measures related to such a complaint, although it may have substance.

Action:

Ensure that facilities for lodging election complaints, providing evidence related to the complaint and attendance ECAP hearings are accessible to people with disabilities.

Ensure that the legal framework guarantees the right to lodge a complaint against any barriers to access for persons with disabilities to the election process, and that ECAP and other judicial authorities are granted powers to undertake remedial actions.

D. Involvement of persons with disabilities in election administration

According to Article 12 of the Law on Training, Vocational Training and Employment of Persons with Disabilities, state administration bodies, private and public sector employers as well as non-governmental organizations are obliged to employ one person with disabilities in every 50 persons employed.

According to the data provided by HandiKOS there are around 200,000 disabled persons in Kosovo. The CEC Secretariat employed 298 Municipal Election Commissioners and 18,832 Polling Station Commissioners, from nominations by political entities, to administer the June 8 elections.

In general, persons with disabilities were underrepresented in election administration bodies. The lists of polling station commission members provided by the CEC, state that 63 of them (0.03% of PSC members) were persons with a disability. Of the 63 persons with disabilities, there were 32 members from HandiKOS and 31 from the Kosovo Association of the Blind; 28% of these were women. The low representation of persons with disabilities in administering the elections indicates that political entities did not take into consideration the nomination of persons with disabilities for election administration positions, and failed to meet the '1 in 50' requirement.

The CEC itself does not appear to perform to the required legal standard for employment of persons with disabilities. Among 11 CEC members and 80 permanent secretariat staff members, none are persons with a disability. The CEC recruited around 8,000 short term workers as technical staff for polling center help desks, distribution of materials, trainers, the Count and Result Center and K-Vote preliminary result system. The CEC has no data available to indicate how many, if any, of these were persons with disabilities. Such record-keeping would assist the CEC to fulfill its legal obligations.

Action:

Respect Kosovo's '1 in 50' rule, which requires that one in fifty employees must be a person with a disability, including by designating within the CEC Secretariat a permanent position with responsibility for inclusiveness and potentially filled by a person with a disability.

Ensure that state administration bodies, private sector employers and NGOs comply with the requirement of Law 3/L-019, to employ at least 1 person with a disability in every 50 employees.

Ensure that persons with disabilities are engaged, in numbers at a minimum sufficient to meet the '1 in 50' rule, as temporary staff during the election period, including as CEC trainers, help desk officers, by-mail processing and Count and Result Center staff, and by enforcing this requirement for nominees by political entities to Municipal Election Commissions and Polling Station Commissions.

E. Voter registration for persons with disabilities

The CEC does not have any database of voters with disabilities, as the voters list is based on a civil registry data extract, which includes only basic personal information such as name, family name, date of birth, and address. The civil registry does not include information indicating whether a citizen has a disability.

Census data generally under-reports the numbers of persons with disabilities: even so, the 2011 census showed 77,730 persons in Kosovo with various disabilities. According to a report of the World Health Organization, it is estimated that around 15% of countries' populations have various disabilities. HandiKOS has 18,000 registered members and estimates around 200,000 persons with disabilities in Kosovo. Other organizations have their own databases for members. However, these data are scattered and are not integrated into one data base.

The lack of exact data on the number of persons with disabilities in Kosovo, and failure to record disability information in the civil registry, and consequently in voter data provided to the CEC, makes it difficult for the CEC to be effective in promoting the electoral participation of, and providing targeted information and voting services to, persons with disabilities.

Action:

Review civil registration procedures to allow, in accordance with requirements for protecting private information, the recording of information about a citizen's disability in the civil register, in order to assist state authorities, including the CEC, to provide better targeted services to persons with disabilities

Regularly update the register of persons with disabilities within each CSO/PWD, promote a national integration of this data and cooperate with election management bodies to support registration, voter information and mobile team voting for persons with disabilities.

7. MONITORING OF PRE-ELECTION AND ELECTION CAMPAIGN

A. Political entities and appointment of persons with disabilities as candidates

According to HandiKOS and DiA data, for the June 8 parliamentary elections, only two political entities, Alliance for the Future of Kosovo (AAK) and “Vetevendosje” Movement (LVV) nominated candidates with disabilities to run for a seat in the Assembly (Xhevdie Peci, AAK and Gëzim Rexha, LVV).

There is no data on whether political entities considered persons with disabilities in the process of selecting candidates, or if any internal quotas are in place to ensure their participation in party structures. The Constitution and the LGE do not provide any quota for political entities to include candidates with disabilities in their candidate lists, as it is the case with the gender quota. Based on the final results of the June 8 Kosovo parliamentary elections, no person with disabilities has been elected as a member of the new parliament. No person with a disability has been elected as a member of the Assembly of Kosovo in any of the past four legislative terms of office.

B. Platforms of political entities

During the electoral campaign the largest political entities have developed and presented their party programs through various electoral activities, including open meetings with interest groups (including HandiKOS and other organizations of persons with disabilities). The analysis below indicates the degree to which political entities have reflected the needs of persons with disabilities in their party programs and electoral platforms:

- Issues of interest for persons with disabilities have been integrated in the main areas such as: sport, education, health, good governance and social services;
- Several political entity programs include concrete policies on disability issues such as building special schools for persons with hearing or visual disabilities, increasing pensions for families who have children with disabilities, handover of responsibilities to CSO/PWDs, building access points/ramps in new school buildings and building entrance points in public and private institutions. In the platforms of some other political entities disability issues are only mentioned in general, with no concrete actions or plans
- Political entity platforms have not been transmitted in a format that is accessible for persons with hearing, visual and intellectual disabilities.

Some examples of political entity platform content targeted at people with disabilities are as follows:

| | LDK | PDK | AAK | LVV | AKR | NISMA |
|-----------------|---|---|---|---|---|--|
| Education | Special attention will be placed on children with disabilities | | Special attention for education of persons with disabilities in order for them not to be marginalized, and for their parents to be able to carry on their jobs and pursue a career. | All new school buildings in Kosovo will be constructed having into consideration the need for easy access of persons with disabilities. | Early education and quality services for children with disabilities. Place special attention in learning foreign languages, develop a rich cultural and sports program, and special parental care for children with disabilities. | Special treatment for children with disabilities, building special schools for persons with hearing and sighting disabilities, as well as groups suffering from Down Syndrome. |
| Health | Strengthening home care services for vulnerable groups (persons with disabilities). | | | | | |
| Social Services | | An increase of income for persons with disabilities at a scale of 25% every year, during the 4 year term. | An increase of pensions for families of children with disabilities. All state institutions will be providing easy access physically, but also prioritize their need on administrative issues. | | | |
| Sport | Support for persons with disabilities and their integration in sports. | | | | | |
| Good Governance | | Advancing cooperation with the civil society by handing over some responsibilities, such as state services for persons with disabilities. | | | Making changes to the current infrastructure to allow for easy access of persons with disabilities. | |

Despite the fact that some political entities have proposed concrete policies for persons with disabilities, they did not consider distributing the program materials in forms accessible for each group of persons with disabilities. Although some political⁵ entities made efforts to print their party programs in suitable formats for persons with visual disabilities in previous elections, in these elections, no political entity printed and distributed materials for persons with visual disabilities (e.g. large format print or Braille script), and consequently messages could only get to them via audio means on radio or television. Similarly, for persons with hearing disabilities, few political entities broadcast spots using sign language. Printed materials and what was accessible through visual content of TV spots were the only means used to reach out to them.

5. AAK, Reformist Party ORA and PDK

Action:

Regularly review political platforms and policies in consultation with CSO/PWDs to ensure that the policies address the concerns of persons with disabilities.

Hold regular consultation meetings with CSO/PWDs to discuss and advance policies on persons with disabilities.

Review the entity's internal statutes and rules and take action to ensure that persons with disabilities are included in party executive and administrative structures, and policy and decision-making processes.

Ensure that persons with disabilities are included in the entity's candidate lists for national and municipal elections.

Ensure persons with disabilities are encouraged to be actively engaged in party administration and activities such as policy development, organizing campaign events, and developing and distributing campaign materials.

Publicize political campaign events among CSO/PWDs, and provide campaign information that is accessible for people with physical, hearing, visual or intellectual disabilities, including using accessible venues for campaign events.

C. Monitoring of political campaign events

During the 10-day election campaign, the LTOs have monitored 321 political events, organized by political entities in the 20 largest municipalities of Kosovo. Observers who were assigned to monitor events in Mitrovica e Veriut/Severna Mitrovica (North Mitrovica) could not attend any events as a result of a decision by political entities in this municipality to boycott the campaign process.

Of the activities monitored, 86 were organized by the Kosovo Democratic Party (PDK), 77 by the Kosovo Democratic League (LDK), 46 by the Self-determination Movement! (LVV), 37 by the Alliance of the Future of Kosovo (AAK), 37 by Alliance New Kosovo (AKR), 22 by Initiative for Kosovo (NISMA) and 16 by other political entities (Figure 1).

Figure 1: Number of political campaign events monitored, by political entity

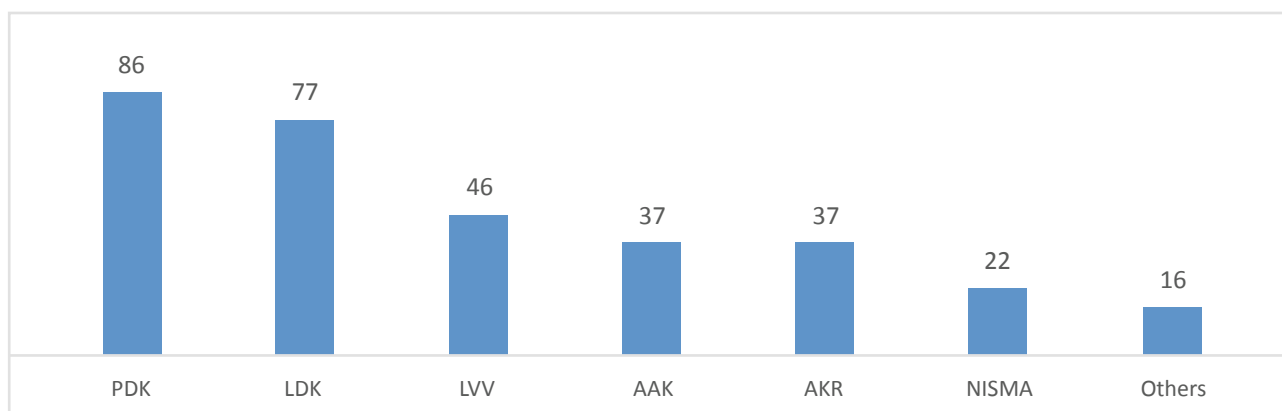

More than two thirds (70%) of the political campaign events were not publicized among CSO/PWDs, which could be an explanation why the participation of persons with disabilities in these events is low. Publicizing events to CSO/PWDs also requires that the information is provided in formats that are accessible for persons with physical, hearing, visual or intellectual disabilities. Of the 30% of the events that were publicized among CSO/PWDs, the information was provided in accessible forms in only 17% of the cases. Even less attention was paid by political entities to providing transport for persons with disabilities. Of 321 campaign activities monitored, transportation for people with disabilities was organized in only 6% of the events (Figure 2).



A candidate greeting observers during an electoral campaign event, Suhareka

Figure 2: Political campaign event’s publication and transportation

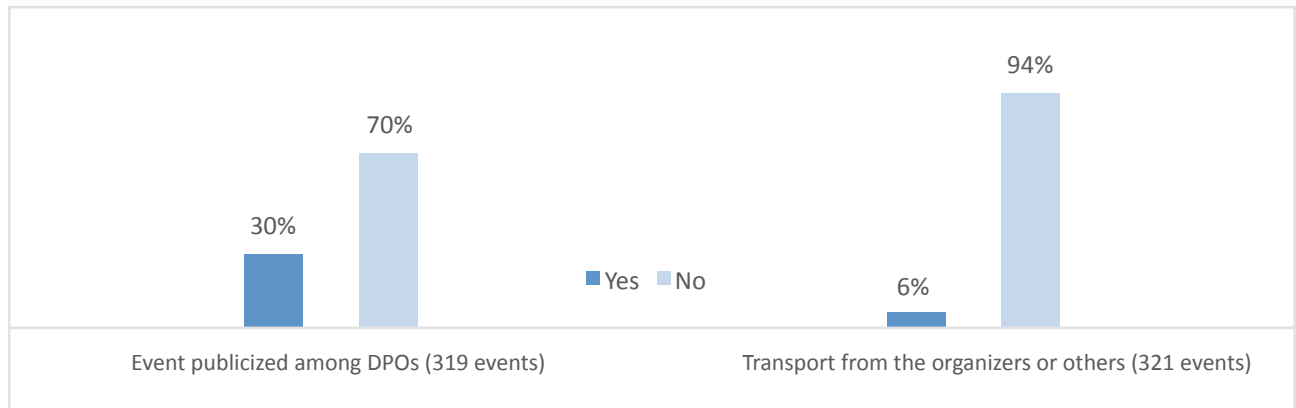

According to the Administrative Instruction on technical conditions of buildings for accessibility for persons with disabilities⁶ issued by the Ministry of Environment and Spatial Planning, physical accessibility for persons with disabilities is a mandatory condition, which should allow for their participation in electoral activities of political entities. Most (93%) of the venues where electoral campaign events were held were not accessible through a ramp or elevator, which inhibits persons with disabilities from participating in such events.

Article 27 of the Administrative Instruction clearly specifies the provisions relating to how seats for persons with disabilities should be allocated/set up for rallies (in halls): however, these requirements were not always taken into consideration by political entities.



Observer monitoring electoral campaign event, Peja

6. http://mmph-rks.org/repository/docs/U_A_per_P_A_K.pdf

In 56% of the campaign events observed, there was no adequate and accessible seating for persons with disabilities. In 60% of the campaign events observed, there was a lack of toilets suitable for persons with disabilities. If the location of and facilities provided for campaign events are not accessible, persons with disabilities will not be able to attend such events.

On the affirmative side, for a majority (53%) of the events observed, persons with a physical disabilities using wheelchairs, were able to move freely in the areas where the campaign event took place. At 93% of the campaign events observed there were no objects hanging on the lower parts of walls, which could hinder the movement of persons in wheelchairs, or of those with visual disabilities (Figure 3).

Figure 3: Access in facilities where political campaign events were held

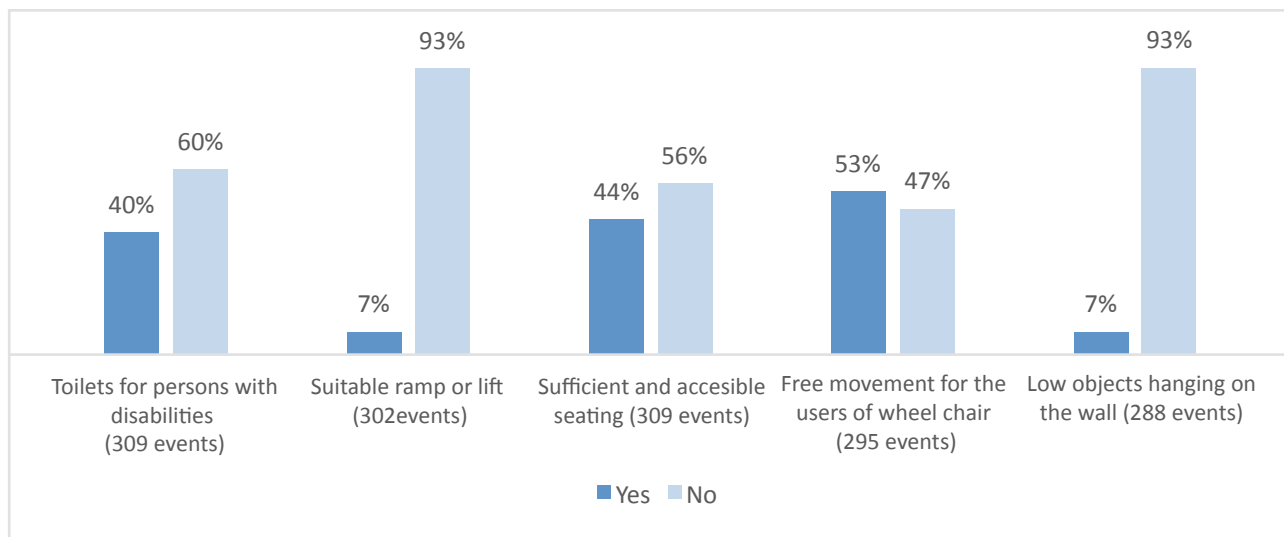

Action:

Conduct assessments of public buildings, including government agencies, local and central civil registration offices, educational facilities and cultural and sports halls, to ensure they meet disability access standards.

Ensure that all political entity administrative offices meet accessibility standards for persons with disabilities.

At the campaign events observed, only 11 speakers with disabilities were reported, of whom 4 were from LDK, 2 from PDK, 2 from LVV, and 1 from each of NISMA, AKR and AAK. Two of the eleven speakers with disabilities were recorded as having a physical disability, whereas for the other speakers no details of the type of disability were recorded. Of the eleven speakers, only a few focused on issues related to disability rights. At 271 of the 321 events observed, it was reported that there were no speakers with disabilities.

The LTOs also assessed the extent to which speakers focused on issues related to disability rights. At 31 of the political events observed (10% of the events) political entity representatives focused on issues related to disability rights. Of these, 10 were at PDK events, 7 at LDK, 5 at LVV, 3 at NISMA,

and 2 at each of AAK, AKR and Conservative Party events. At some of the LDK and PDK events referred to, there was a general discussion about improving the welfare for persons with disabilities by providing employment and educational opportunities. In other events held by LVV and Conservative Party, there was a focus on adopting legislation for protection of the rights of persons with disabilities. During one PDK event, there was a discussion about increasing pensions to improve the social welfare of persons injured during the war.

Action:

CSO/PWDs should monitor the extent to which the political entities and election management bodies address issues related to persons with disabilities in policies and during campaigns, and implement advocacy activities to ensure the rights of people with disabilities are respected.

Ensure persons with disabilities are encouraged to be actively engaged in party administration and activities such as policy development, organizing campaign events, and developing and distributing campaign materials.

The most concerning issue during the political campaign was the lack of information provided in accessible formats for persons with disabilities. A sign language interpreter or live caption for persons with hearing disabilities was provided at only 1% of the 313 electoral activities observed for which this information was recorded. At none of the events observed were campaign materials reported as being made available in a format accessible to persons with visual disabilities (Figure 4).

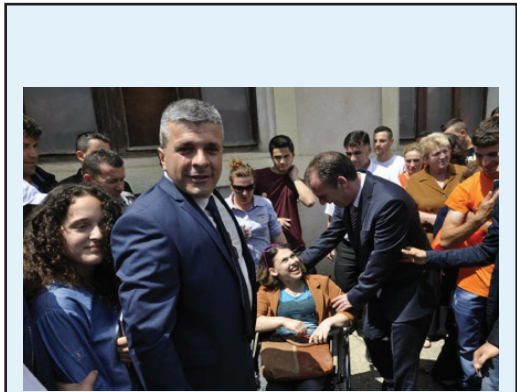

Pranvera Musaj observing campaign event

Pranvera Musaj, 24, is a courageous and a self-taught woman who for years has been helping other women with disabilities to seek employment and succeed in selling handmade artisanal products. At first, as an observer of the campaign she felt a little skeptical of how political parties might perceive her, but to her surprise she encountered great support. She noted that “Being part of this project made me feel equal with others”. While observing, she came across many physical barriers in schools or public buildings, but she says that “barriers are out there to be overcome, this is what I strive for each day”.

Figure 4: Accessible materials for Persons with Disabilities

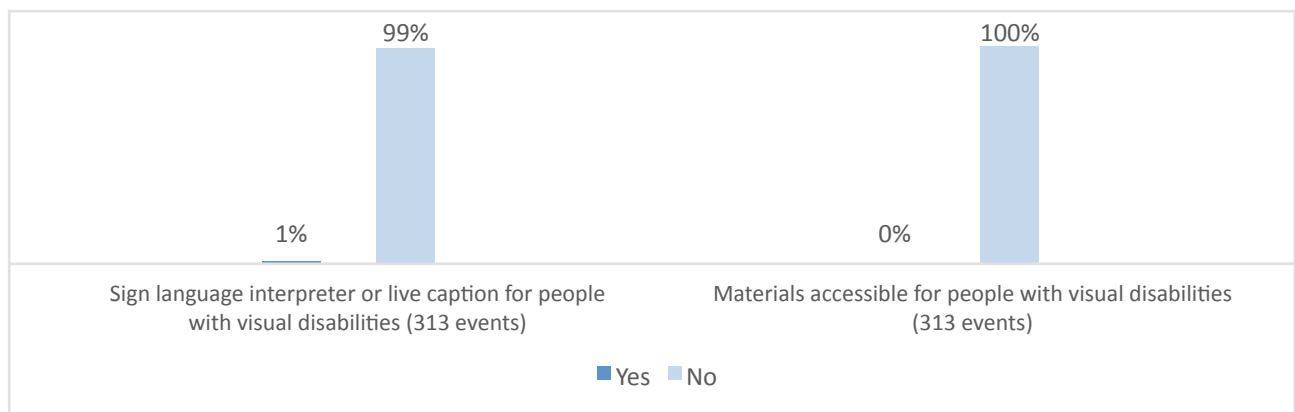

Action:

Publicize political campaign events among CSO/PWDs, and provide campaign information that is accessible for people with physical, hearing, visual or intellectual disabilities, including using accessible venues for campaign events.

D. Meetings with Municipal Election Commission Chairs and members

During the electoral campaign, LTOs held a total of 45 meetings and interviews with Municipal Election Commission chairs and members in 15 Municipalities of Kosovo. During this process, LTOs faced difficulties in participating in formal meetings of the MEC since they were not officially informed about them and information about the time and venue of the meetings was not made public.

Based on the information obtained through interviews with MEC representatives, observers reported that MECs in general have no accurate information regarding voters with disabilities. The number of voters with disabilities known by the MECs in 15 municipalities for which information was provided is around 700. This is a very low figure when compared with HandiKOS estimates of the number of people with disabilities in Kosovo, and the 2011 census data. Limiting knowledge of voters with disabilities to those registered for mobile polling is likely to restrict the effectiveness of electoral services provided to voters with disabilities. Of the municipalities that were covered, based on the information provided by the MECs, the municipality with the highest number of voters with disabilities was Gjilan/Gnjilane with 135 voters. In Gračanica/Gračanica, Viti/Vitina, and Vushtri/Vučitrn, observers could not obtain an answer from MECs on how many persons with disabilities have the right to vote.

In general, it appears issues concerning accessibility for persons with disabilities are not discussed in MEC meetings at a sufficient level. MEC representatives in Lipjan/Lipljan, Deçan/Dečani and Viti/Vitina, advised observers that these issues were rarely discussed. In Suhareka/Suva Reka, Kaçanik/Kaçanik, Gjilan/ Gnjilane, Vushtrri/Vučitrn, Gračanica/Gračanica, Podujeva/Podujevo and Peja/Peć observers were advised that they are discussed occasionally. In Prizren/Prizren, Ferizaj/Uroševac and Mitrovica Jugore/Južna Mitrovica (South Mitrovica) observers were advised that there is a discussion of these issues on a regular basis, whereas in Klinë/Klina and Kamenica/Kamenica MEC representatives advised that issues related to the accessibility of persons with disabilities are discussed in every meeting (Figure 5).

Figure 5: How often do MECs discuss issues related to the accessibility of persons with disabilities (as advised by MEC representatives)

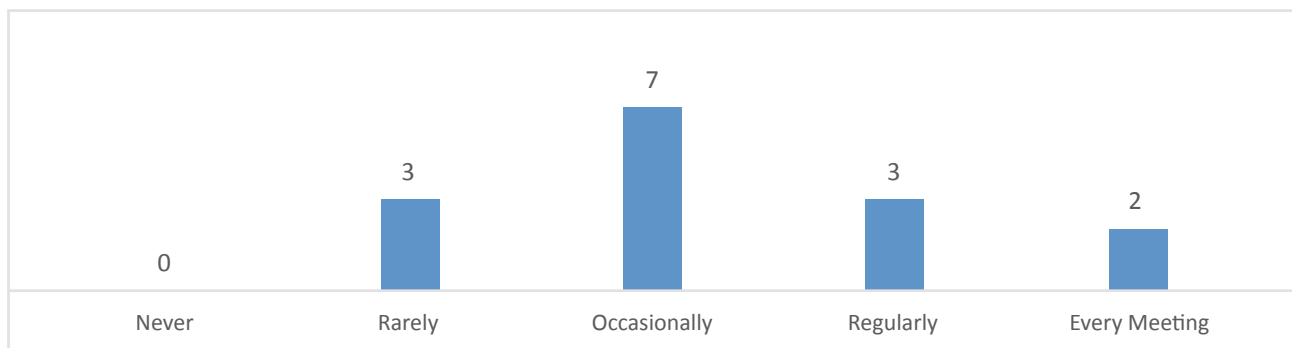

Observers were told by MEC representatives in the municipalities of Suhareka/Suva Reka, Prizren/Prizren, Vushtrri/Vučitrn, Peja/Peć, Mitrovica Jugore/Južna Mitrovica (South Mitrovica), Klinë/Klina, Kaçanik/Kaçanik, Ferizaj/Uroševac, and Gjilan/Gnjilane that MEC representatives did reach out to CSO/PWDs to discuss election accessibility issues. The general assessment by the MECs was that there are obstacles for persons with disabilities to participate in the election process including: the lack of accessible infrastructure in some facilities, the lack of maps, unreliable address system as well as the lack of political will to ensure the participation of persons with disabilities in the process.

From the meetings with MEC representatives in 15 municipalities it appears that there are minimal electoral information campaigns from municipal level for voters with disabilities. The data indicates that MEC representatives did not mention any specific voter information efforts, other than just stating they are in regular contacts with NGOs. Observers could not obtain any information of any community-based campaigns targeting persons with disabilities implemented by the MECs. In Suhareka/Suva Reka, Prizren/Prizren and Mitrovica Jugore/Južna Mitrovica (South Mitrovica), MECs answered that persons with disabilities are informed about the election campaign and election processes in general through HandiKOS and other non-governmental organizations.

Action:

Ensure more regular attention is paid to issues affecting electoral access for persons with disabilities by Municipal Election Officers (MEOs) and MECs. This is more likely if political entities and the CEC ensure that there is more widespread representation of persons with disabilities in MEO and MEC positions.

MEOs and MECs, in coordination with local NGOs and CSOs, including CSO/PWDs, should implement local electoral information activities targeting persons with disabilities, using methodology and content appropriate for each type of disability.

MEOs and MECs can build stronger links with communities of persons with disabilities to have better knowledge of potential voters with disabilities in the municipality and of the electoral services they need.

E. Polling Center pre-election visits

Prior to Election Day, disability access monitors visited 117 randomly selected polling centers during the election campaign period, to assess the accessibility for persons with disabilities. Examination of physical access such as ramps, suitability of toilets, space for wheel chair users was prioritized. The goal of these visits was to identify and advise MECs pre-Election Day of polling centers that would present a problem for voters with disabilities, to allow MECs to improve the facilities where possible.



Observer assessing Polling Center before Election Day

Findings from these visits are shown below (Figure 6). In some cases MECs were able to intervene, even in the short time available.

Figure 6: Accessibility in 117 polling centers visited during the pre-election campaign

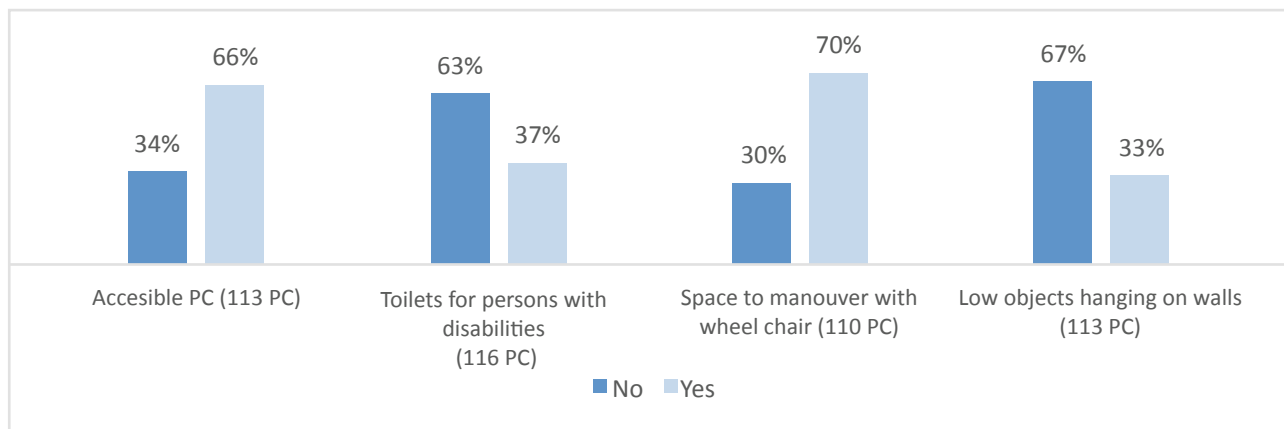

8. MONITORING OF ELECTION DAY

A. Accessibility for persons with disabilities to Polling Centers

Providing conditions for independent movement of persons with disabilities is essential for their participation in public and political life. Promoting participation of persons with disabilities in the electoral process, with special emphasis on Election Day, means providing access to polling centers,⁷ including parking lots. Parking lots were available in 67% of the 488 polling centers observed for which this data was reported, but they were not always designated or marked exclusively for persons with disabilities, in accordance with provisions of Administrative Instruction 33/2007⁸ (Figure 7).

Figure 7: Designated parking place for persons with disabilities

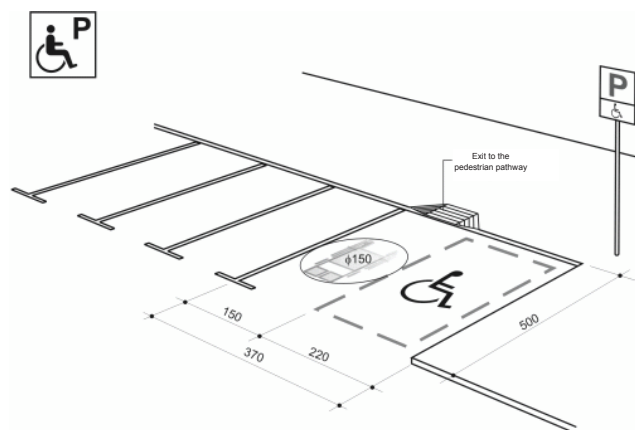

Public areas or pedestrian paths that lead from the parking space to the entrance of the polling center were accessible in the majority of the polling centers. Of 472 polling centers for which this data was reported, pathways were accessible in 321 (68%), while in 151 cases (32%) they were inaccessible; in 181 (37%) of these polling centers, sidewalks and crossings to the voting areas were not free of barriers, posing a hurdle for voters with disabilities to access the polling center.

⁷ Polling centers are facilities of public, educational and cultural institutions, in which one or more polling stations are placed with the aim of voting on elections [...] CEC Regulation 16/2013, Article 1, Paragraph 2.1; Article 3, Paragraph 3.1 j). Article 4, Paragraph 4.1 a);

⁸ Administrative Instruction 33/2007. Article 38, issued by Ministry of Environment and Spatial Planning defines the specifications of parking lots designated for persons with disabilities.



Walkways leading to polling center entrances, Election Day (Primary School in Gllanaselle, Drenas and Primary School "Zenel Hajdini", Terstenik - Drenas)

B. Accessibility for persons with disabilities inside Polling Centers

To ensure unimpeded access, movement or attendance of persons with disabilities, polling centers must meet certain requirements, such as access ramps, suitable toilets, sufficient and convenient seating arrangements, floors with a non-slip surface, and sufficient space for movement, especially for wheelchair users.

Figure 8: Toilet that meets accessibility standards for persons with disabilities

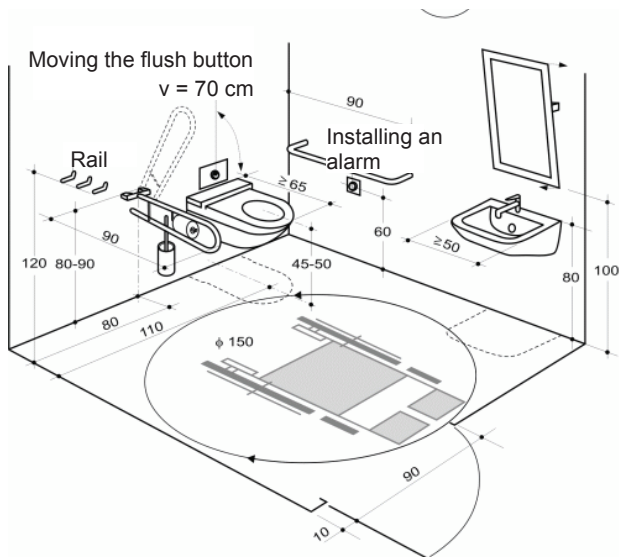

Article 3.1 (h) of CEC Regulation 16/2013 on the establishment of Polling Centers, provides that each polling center must have at least one toilet. Data indicate that 61% (498) of polling centers observed do not possess accessible toilets for persons with disabilities, while 39% have partially accessible restrooms, in that they have a level floor. Article 18 of the Administrative Instruction on the technical construction of accessible facilities for persons with disabilities requires that accessible toilets have a flat floor, an appropriate door with free space for wheelchair movement and maneuver, a toilet seat with at least one drop down rail, low washbasin suitable for wheelchair users, grab rails and other supporting elements (Figure 8).

Figure 9: Ramp for access by persons with disabilities

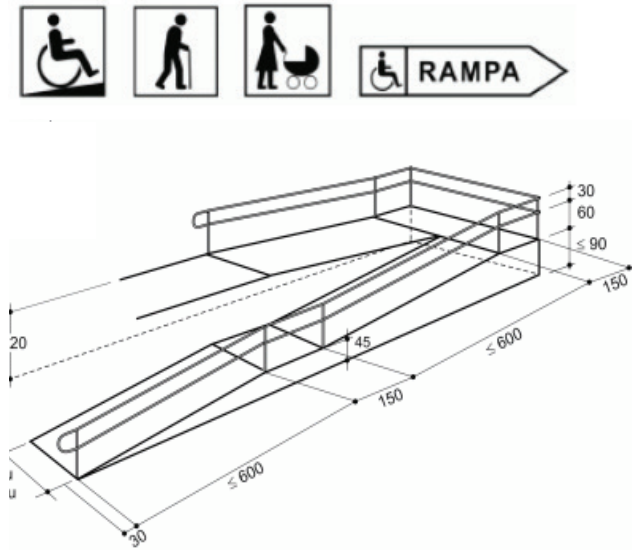

Article 3.1 (f) of the CEC Regulation on the establishment of polling centers also provides that each polling center must be accessible to persons with disabilities. Of 798 polling centers visited on Election Day, by a combination of disability access monitors and DIA's election observation team, 45% had no ground level or ramp access. Even in the 55% of polling centers where access ramps were available, observers assessed that the ramps did not always meet the standards set by administrative instruction of the Ministry of Environment and Spatial Planning⁹ (Figure 9).

Of equal concern is that in some schools equipped with access ramps for persons with disabilities, officials responsible for the polling center didn't allow the ramps to be used, by placing caution tape around them and direction signs that forced voters to use other school entrances that were inaccessible for persons with disabilities.



Polling Center in Polluzha, Drenas



Polling Center "Lec Gradica", Gradica

At almost all polling centers observed, there were no platforms or elevators to allow access for wheelchair users who have been assigned to vote at polling stations on the upper floors of the polling center. To enable them to use their right to vote as equal citizens, wheelchair users had to be carried by their assistants to the upper floors.

⁹. Article 10 of Administrative Instruction 33/2007 issued by the Ministry of Environment and Spatial Planning regarding technical requirements of buildings, provides specifications for ramps (incline allowance up to 5%, appropriate width), to provide access for people with disabilities in public building



Observer monitoring Election Day access at the Primary School “Abedin Rexha” in Kopiliq i Poshtem

Polling center environments such as those described above are a deterrent to voting by persons with disabilities, especially those with physical or visual disabilities, particularly as access to voting using mobile polling teams seems to have become more restricted by changes to mobile voting registration processes. The Disability Access Monitoring team is aware that in certain cases, the CEC is limited to using school buildings as polling centers (even in cases where they do not provide access for persons with disabilities). In rural areas it is difficult to find other adequate buildings for polling, although this does not mean that the CEC and MECs cannot undertake other measures to ensure that on Election Day persons with disabilities can freely and with dignity exercise their right to vote.

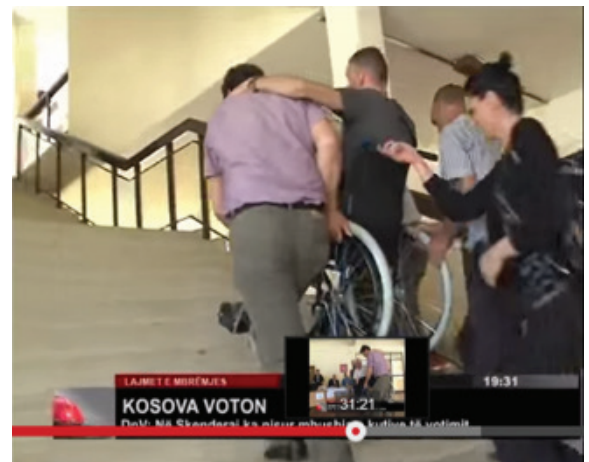

A person on a wheelchair being assisted to access the polling station, Polling Center “Ismail Qemajli” in Prishtina

Figure 10: Space requirements for wheelchair movement

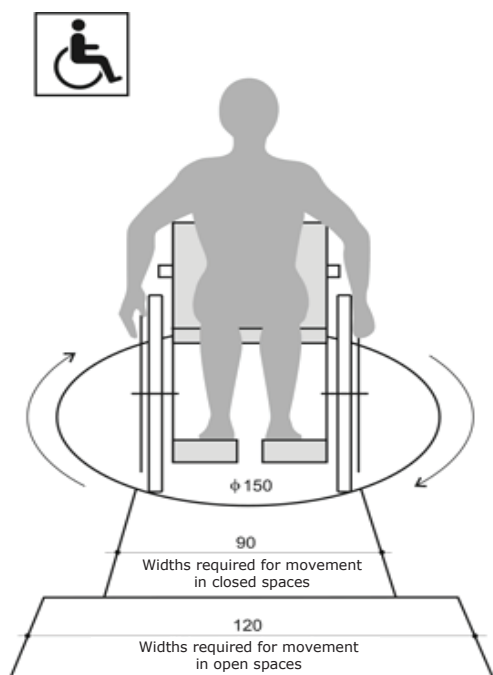

According to standards, a wheelchair user of a moderate size, should have a space with a diameter of at least 1.5 meters to allow unobstructed movement and maneuver (Figure 10). In 54 % of the polling centers observed, and for which relevant information was reported, there was enough space for wheelchair users to move, while in 46% of the polling centers this space was not adequate. Two thirds of the polling centers visited on Election Day had sufficient accessible seats suitable for persons with disabilities.

Reports indicate that in 16% of the polling centers observed and for which relevant information was reported there were low hanging objects on walls that could potentially hinder free movement or be dangerous for persons with disabilities, while in 39% there were floors that were slippery, that could be dangerous for persons with disabilities (Figure 11).

Figure 11: Access inside the facilities of the polling center

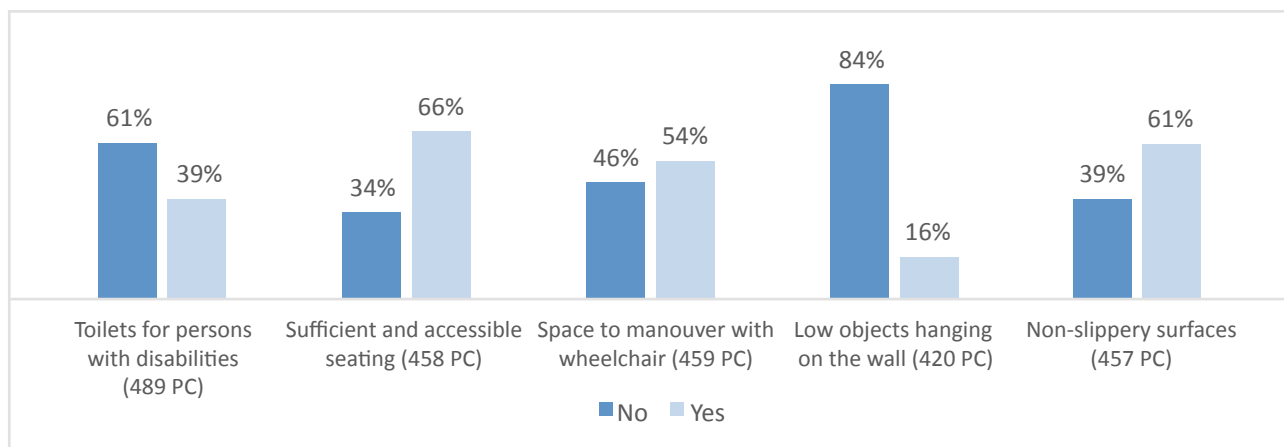

C. The voting process

According to Article 76 of the LGE, political entities represented in Municipal Assemblies are responsible for appointing members to Polling Station Commissions, who then administer the electoral process at their respective polling stations. The representation of persons with disabilities in the polling staff nominated by political entities is very low. Observers recorded only 63 polling stations with a staff member with a disability. Very few observers answered the follow-up question on the type of disability that the PSC member with a disability had, but from those who answered, records show that there were 3 members with vision disabilities, 3 with physical disabilities, and 1 with a hearing disability.

C1. Persons with visual disabilities

During recent years, there have been significant efforts mainly by the Kosovo Association of the Blind to increase the participation of fully and partially vision impaired persons in elections. As a result of these advocacy efforts, in 2009 the CEC took a decision to equip polling centers with Braille ballot guides, so that people with visual disabilities can exercise their right to vote independently. KAB estimates that of the approximately 3,000 potential voters with visual disabilities of whom it is aware, 2,000 are competent in Braille reading.

According to the CEC Secretariat and the KAB, 95% of polling center help desks were equipped with Braille ballot guides, instruction booklets in Braille containing all candidates' names and audio versions. However some did not have these facilities: for example in polling center 2050a in Prizren/Prizren the polling center staff did not have these materials available to assist a vision impaired voter who wanted to vote using the Braille guide. Additionally, polling stations in Kosovo were not equipped with guidelines for the voting process in large letters, or a magnifying glass, to assist persons with visual disabilities.

KAB advised the Disability Access Monitoring team that these materials may not have reached remote polling centers, and that it is concerned that the CEC and MECs did not appear to have trained election staff, especially polling station commissioners, on what these materials are and how they are utilized.

Action:

To improve election access for persons with visual disabilities, ensure that magnifying glasses and good quality Braille and/or tactile ballot marking guides are supplied to all polling stations.

Ensure that the Braille ballot guides reach every polling center and that polling station commissioners are trained for their use.

C2. Persons with physical disabilities

Voting compartments (Figure 12) used in almost all elections in Kosovo since 2000, have the following specifications:

- Height: 150 cm
- Width: 54 cm
- Depth: 40 cm
- Height from the floor to the surface for writing 76 cm
- Thickness of cardboard: 0.3-0.5 cm
- Folded and resistant to moisture

Figure 12: Voting compartment used in Kosovo parliamentary elections, 2014

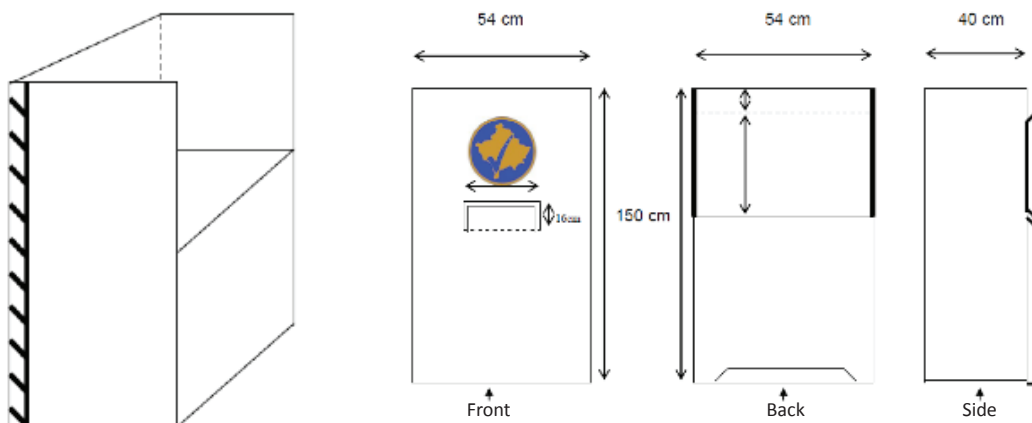

The Disability Access Monitoring team considers that the writing surface of the voting booth was sufficiently low (76cm) for accessibility by persons in wheelchairs, but the width of 54 cm and depth of 40 cm, and particularly the closed front of the voting compartment, prevents voters in wheelchairs from entering the voting compartment. Also, the voting compartment was not sufficiently strong to support voters who use other means for movement (crutches, cane), it was very difficult for them to vote themselves, in secrecy. The quality of the cardboard used in the voting compartments is not good enough to offer them sufficient support.



The voting compartment does not have adequate space to allow voters in wheelchairs to get into the voting booth

Additionally, in some polling stations ballot boxes were placed on tables at a height so that persons in wheelchairs could not reach the ballot box slot to insert their ballot paper, and had to rely on others to do this for them. These flaws in polling equipment and polling station layout seriously breach the right guaranteed by the Kosovo Constitution that all voters may vote in secret. Reports from 442 of the polling centers visited by disability access monitors on Election Day, indicate that in 45% of these polling centers a person in a wheelchair would have difficulty in placing his/her ballot in the ballot box without assistance.

Figure 13: Model specifications for wheelchair accessible voting compartment

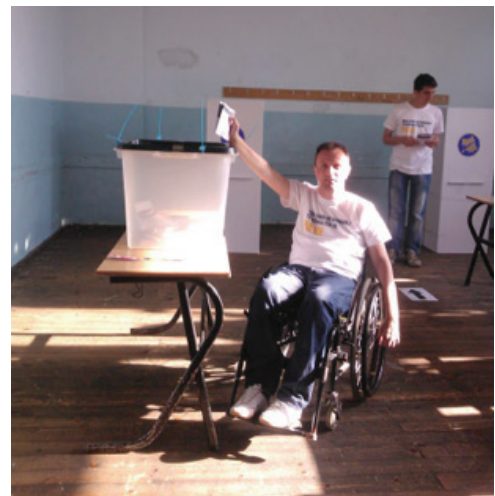
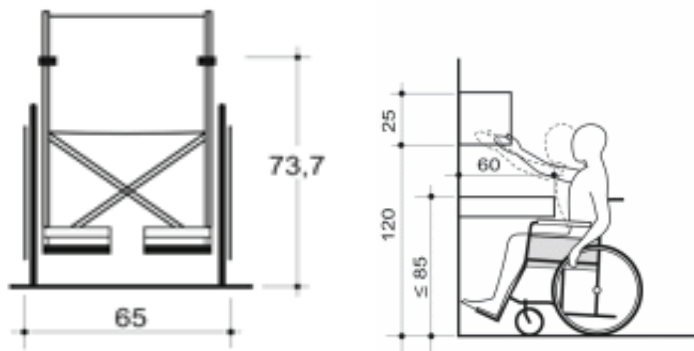

Ballot box too high to reach for voter on wheelchair

Action:

Revise polling equipment specifications and set-up instructions to ensure persons with physical disabilities can access voting compartments and ballot boxes to vote in secret and without assistance. Consider the provision of one table-top voting compartment per polling station.

Post-Election: Visit to the Count and Results Center

On June 23rd, an STO visited the Count and Results Center to assess the counting process of the votes cast using mobile teams for “people with special needs”. The CRC is considered partially accessible for people with disabilities; the entrance of the building meets the standards for wheelchair users, however rest rooms were located out of the building and were inaccessible. A significant finding that came out of this visit was that out of the almost 600 CRC staff, only two people with disabilities were engaged in the counting process.

9. GOOD PRACTICES

The following are some examples of international good practices instituted by electoral management bodies to support the electoral rights of persons with disabilities.

In the Dominican Republic, a Memorandum of Understanding between the Junta Central Electoral (JCE) and 18 local CSO/PWDs was signed in 2012. This agreement, which was the first the JCE has ever signed with CSO/PWDs, promoted collaboration between these groups on ways to improve inclusion and election access for persons with disabilities.

The Macedonian CSO/PWD, Poraka, drafted and promoted a pledge for political parties to ratify the United Nations Convention on the Rights of Persons with Disabilities (CRPD) within 100 days of the formation of the new government in 2011. Poraka used the signed pledge to gain widespread press coverage of the need to ratify the CRPD. Following this campaign, the Macedonian Assembly unanimously ratified the CRPD in 2011.

In Albania, as a result of a decision of the Central Election Commission to no longer use mobile ballot boxes, in 2003 the Albanian Disability Rights Foundation (ADRF), conducted a survey with school children in five middle schools. The eighth graders – representing 647 households – were asked if any members of their household were unable to vote as a result of this decision. 11% reported that at least one person in their household was not able to vote because of a short or long term disability. The ADRF re-opened a dialogue with the Central Election Commission, political parties and other stakeholders, on the rights of all voters, including homebound voters, to cast a ballot.

In Guatemala during the 2011 elections, young persons with Downs Syndrome helped Guatemala's Supreme Electoral Tribunal (TSE) assemble election materials. Young Guatemalans served as sign language translators during television broadcasts of electoral messages. Featuring these volunteers in promotional materials and public service announcements sensitized the general public to the abilities of persons with disabilities.

In Slovenia in 2003, the Constitutional Court reviewed whether the requirements of the Law on Elections for Slovenian Parliament, the Law on Presidential Elections and the Law on Local Elections for registering only people with full legal capacity were in compliance with the constitution. The Constitutional Court decided that these election laws were unconstitutional.

In Sierra Leone, a coalition of CSOs including a CSO/PWD drafted a code of conduct for political parties running in the November 2012 elections. The document was intended to, among other things, encourage women and other marginalized groups to participate in the election process. The code explicitly states that parties will include women and persons with disabilities in the candidate lists. The code of conduct provided a standard to which CSOs can hold political parties accountable during the campaign period. The initiative has been promoted in the media and it has been distributed to party offices throughout the country.



USAID
NGA POPULLI AMERIKAN
OD AMERIČKOG NARODA

